

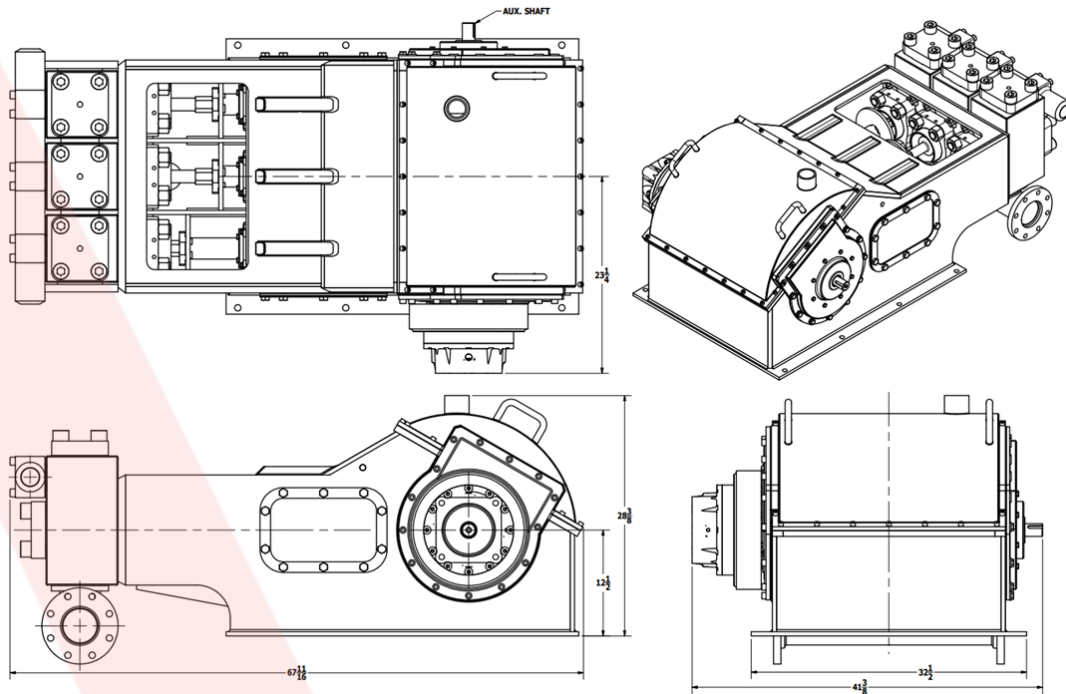

American Mud Pumps® provides **smooth triplex performance** and high efficiency pumps, for continuous duty rated drilling and workover operations.

The pump's light weight and flexible design make it **easily adaptable** to a variety of rig configurations and drilling requirements and conditions changes throughout.



#### Features

- Minimum weight/maximum performance with continuous duty life expectancy.
- High performance high strength steel fabricated power end.
- High pressure plunger arrangements available upon request.
- Optional external reduction ratio in chain or gear.
- Anti-friction roller bearings throughout.
- Forged steel eccentric crankshaft.
- Double (redundant) failsafe internal tube system.
- Metal to metal liner lock.

#### Technical specification data

Input horsepower rating at 235 SPM	420
Input horsepower rating at 300 SPM	300
Stroke length	5.00"
Maximum piston size	5.00"
Fluid end working pressure rating	5,000 Psi
Piston rod load	30,700 Psi
Discharge connection size	3.00" Union
Suction connection size	4.00" Flange
Crankcase oil capacity	30 Gallons
Liner wash capacity	25 Gallons
Pump weight complete (Less skid)	9,750 Lbs
Overall dimensions (L x W x H)	67.68" X 41.37" X 28.37"

AMP-300A High Performance 5.00" Stroke Triplex		Strokes Per Min.	75	125	175	225	275	325
		Input HP*	96	160	225	290	355	420
Piston Size	Discharge Pressure Rating	Output Gal/ Rev	Output – Gallons Per Minute**					
5.00"	1,650	1.275	96	159	223	287	351	414
4.50"	2,038	1.033	77	129	181	232	284	336
4.00"	2,579	0.816	61	102	143	184	224	265
3.50"	3,368	0.625	47	78	109	141	172	203
3.00"	4,584	0.459	34	57	80	103	126	149
2.75"	5,000*	0.386	29	48	67	87	106	125

\*Based on 95% mechanical efficiency, \*\*Based on 100% volumetric efficiency.



American Mud Pumps Inc

3050 Post Oak Blvd. Suite 510,  
Houston TX. 77056 United States of America

Main: +1 (713) 979-0533

Fax: +1 (713) 979-0534

customerservice@americanmudpumps.com [www.americanmudpumps.com](http://www.americanmudpumps.com)



Connect with our expert team today!

