

Drilling and Workover

QUINTUPLEX

AMPQ-800L (64~1,028 GPM)

Technical specification data	
Input horsepower rating	800
Pump speed	280
Stroke length	6.00"
Maximum piston size	5.50"
Fluid end working pressure rating	7,500 Psi
Discharge connection size	4.00" Flange
Suction connection size	6.00"/8.00" Flange
Crankcase oil capacity	90 Gallons
Linerwash capacity	60 Gallons
External gear ratio (other ratios available)	4.61: 1
Pump weight complete (Less skid)	11,200 Lbs
Overall dimensions (L x W x H)	86.31" X 80.68" X 36"

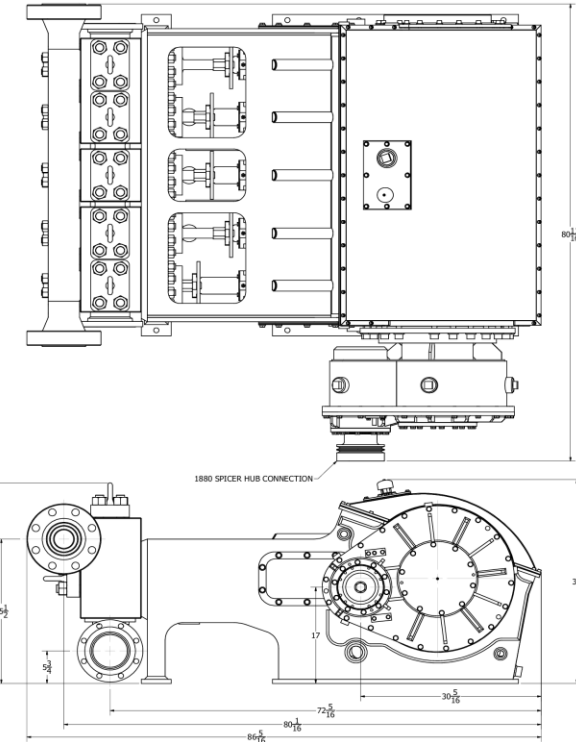
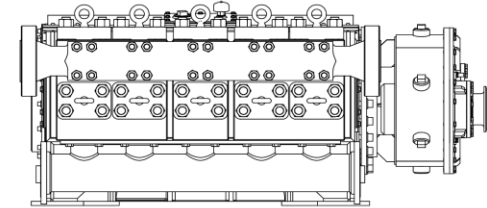
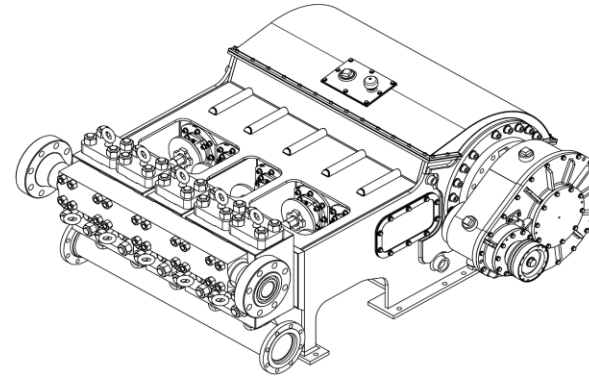

Features

- Minimum weight/maximum performance with continuous duty life expectancy.
- 33% increase in MWD/LWD frequency bandwidth.
- 66% increase in the MWD/LWD data transfer rate.
- Four main bearing design eliminates crankshaft deflection.
- High performance structural steel fabricated power end.
- Anti-friction roller bearings throughout.
- Forged steel eccentric crankshaft.
- Double (redundant) failsafe internal lube system.
- Metal to metal liner lock.

AMPQ-800L High Performance 6.00" Stroke Quintuplex		Strokes Per Min.	100	140	160	200	240	260	280
		Input HP*	286	400	457	571	686	743	800
Piston Size	Discharge Pressure Rating	Output Gal/Rev	Output – Gallons Per Minute**						
6.00" ***	1,267	3,672	367	514	588	734	881	955	1028
5.50" ***	1,508	3,086	309	432	494	617	741	802	864
5.00"	1,824	2,550	255	357	408	510	612	663	714
4.50"	2,252	2,066	207	289	330	413	496	537	578
4.00"	2,851	1,632	163	228	261	326	392	424	457
3.50"	3,723	1,250	125	175	200	250	300	325	350
3.00"	5,068	0,918	92	129	147	184	220	239	257
2.50"	7,298	0,638	64	89	102	128	153	166	179

* Based on 95% mechanical efficiency, **Based on 100% volumetric efficiency, *** Piston only.