

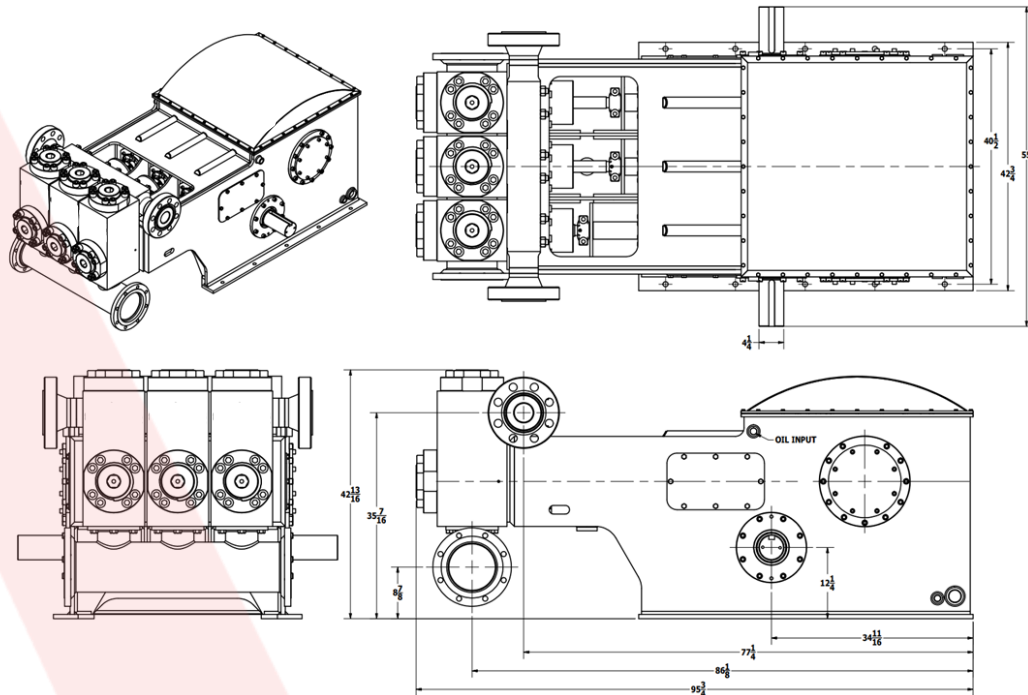

American Mud Pumps® provides **smooth triplex performance** and high efficiency pumps, for continuous duty rated drilling and workover operations.

The pump's light weight and flexible design make it **easily adaptable** to a variety of rig configurations and drilling requirements and conditions changes throughout.



Features

- Minimum weight/maximum performance with continuous duty life expectancy.
- High performance high strength steel fabricated power end with steel herringbone gears.
- Low pinion shaft design with hydrostatic lubrication system.
- High pressure plunger arrangements available upon request.
- Anti-friction roller bearings throughout.
- Forged steel eccentric crankshaft.
- Double (redundant) failsafe internal lube system.
- Metal to metal liner lock.

Technical specification data

Input horsepower rating	500
Pump speed	240
Stroke length	7.00"
Maximum piston size	6.75"
Fluid end working pressure rating	5,000 Psi
Discharge connection size	4.00" Union
Suction connection size	8.00" Flange
Crankcase oil capacity	40 Gallons
Liner wash capacity	40 Gallons
Internal gear ratio (other ratios available)	5.21: 1
Pump weight complete (Less skid)	9,750 Lbs
Overall dimensions (L x W x H)	90.75" X 55" X 42.81"

AMP-500 High Performance 7.00" Stroke Triplex		Strokes Per Min.	70	100	140	170	200	220	240
		Input HP**	146	208	292	354	417	458	500
Piston Size	Discharge Pressure Rating	Output Gal/Rev	Output – Gallons Per Minute***						
6.75" *	1,043	3,253	228	325	455	553	651	716	781
6.50" *	1,125	3,017	211	302	422	513	603	664	724
6.00"	1,320	2,570	180	257	360	437	514	565	617
5.50"	1,571	2,160	151	216	302	367	432	475	518
5.00"	1,900	1,785	125	176	250	303	357	393	428
4.50"	2,346	1,446	101	145	202	246	289	318	347
4.00"	2,969	1,142	80	114	160	194	228	251	274
3.50"	3,878	0.875	61	87	122	149	175	192	210
3.00"	5,000	0.643	45	64	90	109	129	141	154

* Requires a special wear plate, ** Based on 95% mechanical efficiency, ***Based on 100% volumetric efficiency.



American Mud Pumps Inc

3050 Post Oak Blvd. Suite 510,
Houston TX. 77056 United States of America

Main: +1 (713) 979-0533

Fax: +1 (713) 979-0534

customerservice@americanmudpumps.com www.americanmudpumps.com



Connect with our expert team today!

